

Proportional 3-way throttle cartridges

high dynamics, with two position transducers, sizes from 25 to 80

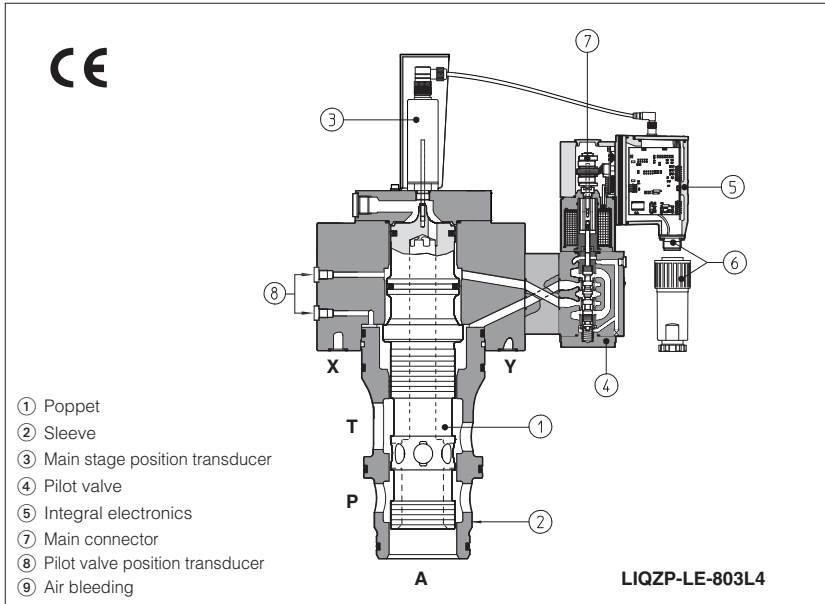

1 MODEL CODE

LIQZO - LES - PS - 25 3 L4 / * ** /*

Flow control valve
LIQZO
 size 16 to 40,
 Pmax 350 bar
LIQZP
 size 50 to 80,
 Pmax 420 bar

L = with two position integral transducers
LE = as L plus integral electronics
LES = as L plus integral digital electronics **obsolete (1)**

Communication interfaces (only for LES)
PS = Serial
BC = CANbus
BP = PROFIBUS-DP

Valve size, see section 3
LIQZO: 25, 32, 40
LIQZP: 50, 63, 80

Valve configuration, see section 3
3 = 3 way

Spool type (regulating characteristics):
L4 = linear

Note (1): This execution of LES digital valves is **obsolete** and no more available. For new execution of LES digital valves, see table FS340

Seals material:
 omit for NBR (mineral oil & water glycol)
PE = FPM

Series number

Hydraulic options
A = reversed hydraulic configuration of main spool: P-A in rest position

Electronic options for -LE execution
 see section 6:
F = fault signal
I = current reference input and monitor (4÷20 mA)
Q = enable signal
Z = enable, fault and monitor signal (12 pin connector)

Electronic options for -LES execution
 see section 6:
I = current reference input and monitor (4÷20 mA)
Z = double power supply, enable, fault and monitor signals (12 pin connector)

Special options for -LES execution
 see section 6:
SL = additional closed loop force control with one remote load cell
SP = additional closed loop pressure control with one remote pressure transducer
C = current feedback interface for transducer(s) **only for options /SL, /SP**

LIQZO-L* and **LIQZP-L*** are 3-way proportional cartridge valves, with double position transducer designed for mounting in manifold blocks which provide both directional and non compensated flow control according to electronic reference signal.

They operate in association with electronic drivers, see section 2, which supply the proportional valves with proper current to align valve regulation to the reference signal supplied to the electronic driver.

They are available in different executions:

- -L, with two integral position transducers ③, ⑧;
- -LE, -LES as -L plus analogue (LE) or digital (LES) integral electronics ⑤.

The regulation is operated by means of a spool ① with double piloting area sliding into a sleeve ② and provided of integral LVDT position transducer ③.

The spool is operated by means of a high performances proportional directional valve ④ in "rugged" executions to withstand high vibrations and mechanical stresses (type DLHZO for cartridge dimensions up to size 50 and type DLK-ZOR for cartridge dimensions up to size 80) - see tab. F180, provided of high precision sleeve and LVDT position transducer ⑧ for maximum regulating accuracy and dynamic response. It is controlled in double closed loop position by means of the LVDT position transducers ③ and ⑧.

The integral electronics ⑤ ensures factory presetting, fine functionality plus valve-to-valve interchangeability and simplified wiring and installation.

Standard 7 pin main connector is used for power supply, analog input reference and monitor signals.

12 pin connector is used for options /Z and /S*.

The special /S* options add a closed loop control of pressure (/SP) or force (/SL) to the basic closed loop spool position one.

Following communication interfaces ⑦ are available for the digital -LES execution:

- -PS, Serial communication interface for configuration, monitoring and firmware updating through Atos PC software
- -BC, CANopen interface
- -BP, PROFIBUS DP interface

The valves with -BC and -BP interfaces can be integrated into a fieldbus communication network and thus digitally operated by the machine control unit.

Typical applications: plastic injection and blow moulding, ceramics, punching & nibbling machines, die-casting, foundry and sheet machinery;

Sizes from 25 to 80

LIQZO: sizes from **25 to 40**,
 Max flow: **500 to 1050 l/min**
 Max pressure: **350 bar**

LIQZP: sizes from **50 to 80**,
 Max flow: **2000 to 5000 l/min**
 Max pressure: **420 bar**

2 ELECTRONIC DRIVERS FOR LIQZO-L*

Valve model	-L	-LE	-LES	-LES / SL, SP
Drivers model	E-ME-L	E-RI-LE	E-RI-LES	E-RI-LES, /SL, /SP
Data sheet	G150	G200	G210	G212

Note: For power supply and communication connector see section 15

3 HYDRAULIC CHARACTERISTICS (based on mineral oil ISO VG 46 at 50 °C) (3)

Hydraulic symbols						
	LIQZ*-L		LIQZO-L*		LIQZ*-L*/A	
Model	LIQZO-L*			LIQZP-L*		
Size	25	32	40	50	63	80
Max regulated flow at $\Delta p = 5$ bar	185	330	420	780	1250	2100
at $\Delta p = 10$ bar	260	470	590	1100	1750	3000
Max permissible flow	500	850	1050	2000	3100	5000
Max pressure [bar]	Ports A, B = 350		X = 350	Y \leq 10	Ports A, B = 420	
Nominal flow of pilot valve at $\Delta p = 70$ bar [l/min]	4	7	28	40	40	40
Leakage of pilot valve at P = 100 bar [l/min]	0,2	0,2	0,5	0,7	0,7	0,7
Response time $\pm 100\%$ step signal [ms]	22	25	27	28	30	31
Pilot volume [cm ³]	2,16	7,2	8,9	17,7	33,8	42,7
Hysteresis [% of the regulated max flow]	$\leq 0,1\%$					
Repeatability [% of the regulated max flow]	$\pm 0,1\%$					
Thermal drift	zero point displacement < 1% at $\Delta T = 40^\circ\text{C}$					

Note:

Above performance data refer to valves coupled with Atos electronic drivers, see section 2.

- Recommended piloting pressure is 140 ÷ 160 bar.
- In case of long time shutdown of the hydraulic supply to the pilot valve, the driver has to be switched off to avoid its overheating.

4 GENERAL NOTES

LIQZO-L* proportional cartridges are CE marked according to the applicable Directives (e.g. Immunity/Emission EMC Directive and Low Voltage Directive).

Installation, wirings and start-up procedures must be performed according to the general prescriptions shown in table F003 and in the installation notes supplied with relevant components.

The electrical signals of the valve (e.g. monitor signals) must not be directly used to activate safety functions, like to switch-ON/OFF the machine's safety components, as prescribed by the European standards (Safety requirements of fluid technology systems and components-hydraulics, EN-982).

4.1 Option /A

The standard valve version provides the hydraulic configuration A-T of main spool in absence of electric power supply to the valve.

The option /A provides the reversed configuration P-A of main spool in absence of electric power supply to the valve.

This execution is particularly requested in vertical presses for safety reasons, because in case of electric power breakdown the valve P-A configuration of the main spool prevents the uncontrolled and dangerous downstroke of the press ram.

5 CONNECTIONS FOR -L EXECUTION

SOLENOID POWER SUPPLY CONNECTOR 666	
PIN	Signal description
1	SUPPLY
2	SUPPLY
3	GND

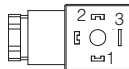

PILOT VALVE POSITION TRANSDUCER CONNECTOR 345	
PIN	Signal description
1	OUTPUT SIGNAL
2	SUPPLY -15 V _{DC}
3	SUPPLY +15 V _{DC}
4	GND

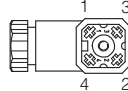

MAIN STAGE POSITION TRANSDUCER CONNECTOR 345	
SIZES 25 ÷ 40	
PIN	Signal description
1	OUTPUT SIGNAL
2	SUPPLY -15 V _{DC}
3	SUPPLY +15 V _{DC}
4	GND

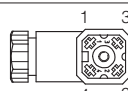

MAIN STAGE POSITION TRANSDUCER CONNECTOR ZBE-08	
SIZES 50 ÷ 80	
PIN	Signal description
1	PROG
2	VT+
3	AGND
4	TR
5	VT-

Technical specification	
1	do not connect
2	Power supply reference +15 VDC
3	Common GND for transducer power & signal
4	Transducer output signal
5	Power supply reference -15 VDC

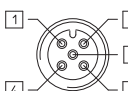

6 ANALOG INTEGRAL DRIVERS -LE - OPTIONS

Standard driver execution provides on the 7 pin main connector:

- Power supply** - 24V_{DC} must be appropriately stabilized or rectified and filtered; a 2,5 A safety fuse is required in series to the driver power supply. Apply at least a 10000 $\mu\text{F}/40$ V capacitance to single phase rectifiers or a 4700 $\mu\text{F}/40$ V capacitance to three phase rectifiers
- Reference input signal** - analog differential input with ± 10 V_{DC} nominal range (pin D,E), proportional to desired valve spool position
- Monitor output signal** - analog output signal proportional to the actual valve's spool position with ± 10 V_{DC} nominal range

Following options are available to adapt standard execution to special application requirements:

6.1 Option /F

It provides a Fault output signal in place of the Monitor output signal, to indicate fault conditions of the driver (cable interruption of spool transducers or reference signal - for /I option): Fault presence corresponds to 0 V_{DC}, normal working corresponds to 24 V_{DC}.

6.2 Option /I

It provides the 4÷20 mA current reference and monitor signals instead of the standard ± 10 V_{DC}

It is normally used in case of long distance between the machine control unit and the valve or where the reference signal can be affected by electrical noise; the valve functioning is disabled in case of reference signal cable breakage.

6.3 Option /Q

It provides the possibility to enable or disable the valve functioning without cutting the power supply (the valve functioning is disabled but the driver current output stage is still active). To enable the driver supply a 24V_{DC} on the enable input signal.

6.4 Option /Z

This option includes /F and /Q features, plus the Monitor output signal.

When the driver is disabled (0 V_{DC} on Enable signal) Fault output is forced to 0 V_{DC}.

6.5 Possible combined options: /FI and /IZ

7 ANALOG INTEGRAL DRIVERS -LE - MAIN FUNCTIONS AND ELECTRONIC CONNECTIONS

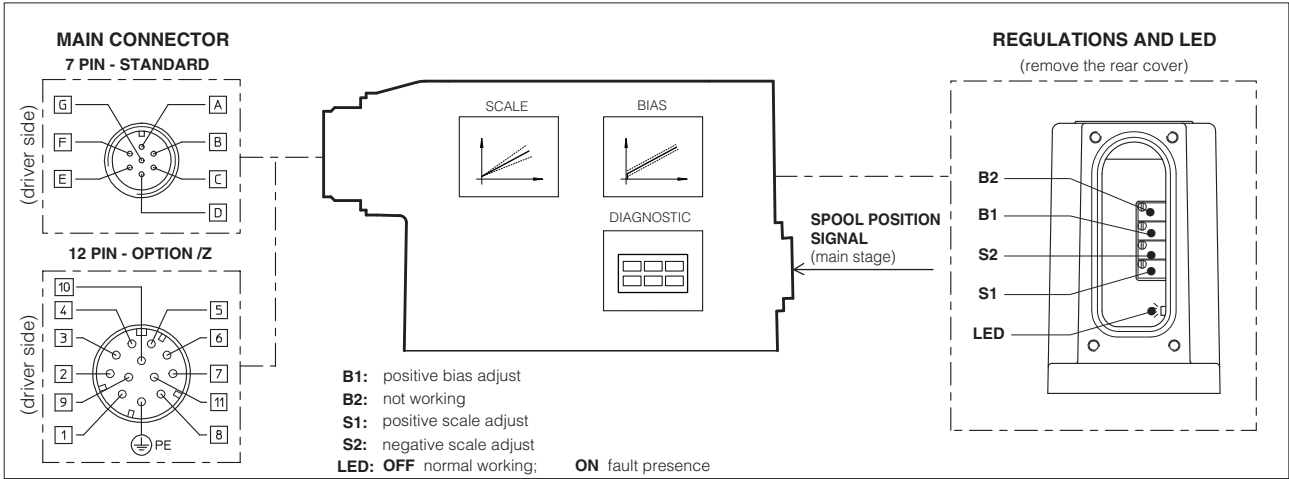

7.1 ELECTRONIC CONNECTIONS - 7 & 12 PIN MAIN CONNECTORS

Standard 7pin	/Z option 12pin	SIGNAL	TECHNICAL SPECIFICATIONS	NOTES
A	1	V+	Power supply 24 Vdc for solenoid power stage and driver logic	Input - power supply
B	2	V0	Power supply 0 Vdc for solenoid power stage and driver logic	Gnd - power supply
C (1)	7	AGND	Ground - signal zero for MONITOR signal (for standard, /Z option)	Gnd - analog signal
	3	ENABLE	Enable (24 Vdc) or disable (0 Vdc) the driver (for /Q and /Z options)	Input - on/off signal
D	4	INPUT+	Reference analog differential input: ± 10 Vdc maximum range (4 ÷ 20 mA for /I option)	Input - analog signal
E	5	INPUT -		
F (2)	6	MONITOR	Monitor analog output: ± 10 Vdc maximum range (4 ÷ 20 mA for /I option)	Output - analog signal
	11	FAULT	Fault (0V) or normal working (24V) (for /F and /Z option)	Output - on/off signal
-	8	R_ENABLE	Repeat Enable - output repetition of Enable input	Output - on/off signal
-	9	NC	do not connect	Output - on/off signal
-	10	NC	do not connect	Output - on/off signal
G	PE	EARTH	Internally connected to the driver housing	

Notes:

- (1) with /Q option ENABLE signal replaces AGND on pin C; MONITOR signal is referred to pin B
(2) with /F option FAULT signal replaces MONITOR on pin F.

- A minimum time of 50ms to 100ms have be considered between the driver energizing with the 24 Vdc power supply and when the valve is ready to operate. During this time the current to the valve coils is switched to zero.

8 DIGITAL INTEGRAL DRIVERS -LES - OPTIONS

Standard driver execution provides on the 7 pin main connector:

- Power supply** - 24Vdc must be appropriately stabilized or rectified and filtered; a 2,5 A safety fuse is required in series to each driver power supply
Apply at least a 10000 μ F/40 V capacitance to single phase rectifiers or a 4700 μ F/40 V capacitance to three phase rectifiers
- Reference input signal** - analog differential input with ± 10 Vdc nominal range (pin D,E), proportional to desired valve spool position
- Monitor output signal** - analog output signal proportional to the actual valve's spool position with ± 10 Vdc nominal range

Following options are available to adapt standard execution to special application requirements:

8.1 Option /I

It provides 4÷20 mA current reference and monitor signals instead of the standard ± 10 V.

It is normally used in case of long distance between the machine control unit and the valve or where the reference signal can be affected by electrical noise; the valve functioning is disabled in case of reference signal cable breakage.

8.2 Option /Z

It provides on the 12 pin main connector the following additional features:

Logic power supply

Separated power supply for the solenoid (pin 1, 2) and for the digital electronic circuits (pin 9, 10).

Cutting solenoid power supply allows to interrupt the valve functioning but keeping energized the digital electronics thus avoiding fault conditions of the machine fieldbus controller. This condition allows to realize safety systems in compliance with European Norms EN13849-1 (ex EN954-1).

Enable Input Signal

To enable the driver, supply 24Vdc on pin 3 referred to pin 2: when the Enable signal is set to zero the valve functioning is disabled (zero current to the solenoid) but the driver current output stage is still active.

Fault Output Signal

Fault output signal indicates fault conditions of the driver (solenoid short circuits/not connected, reference signal cable broken for 4÷20mA input, etc.). Fault presence corresponds to 0 Vdc, normal working corresponds to 24Vdc (pin 11 referred to pin 2): Fault status is not affected by the Enable input signal

8.3 Options /SP and /SL

These options add the closed loop control of pressure (/SP) or force (/SL) to the basic functions of proportional directional valves: a dedicated software alternates pressure (force) and valve's spool position controls depending on the actual hydraulic system conditions.

A dedicated connector is available for the additional transducers that are required to be interfaced to the valve's driver (1 pressure transducer for /SP or 1 load cell for /SL).

Main 12 pin connector is the same as /Z option plus two analog signals specific for the pressure (force) control: one for reference (pin 7) and one for monitor (pin 8).

For further details please refer to the driver technical table **G212**.

8.4 Options /C

Options /CSP and /CSL are available to connect pressure (force) transducers with 4 ÷ 20mA current output signal.

8.5 Possible combined options: /ISP, ISL, /CSP, /CSL, /CISP, /CISL and /IZ

9 DIGITAL INTEGRAL DRIVERS -LES - MAIN FUNCTIONS AND ELECTRONIC CONNECTIONS

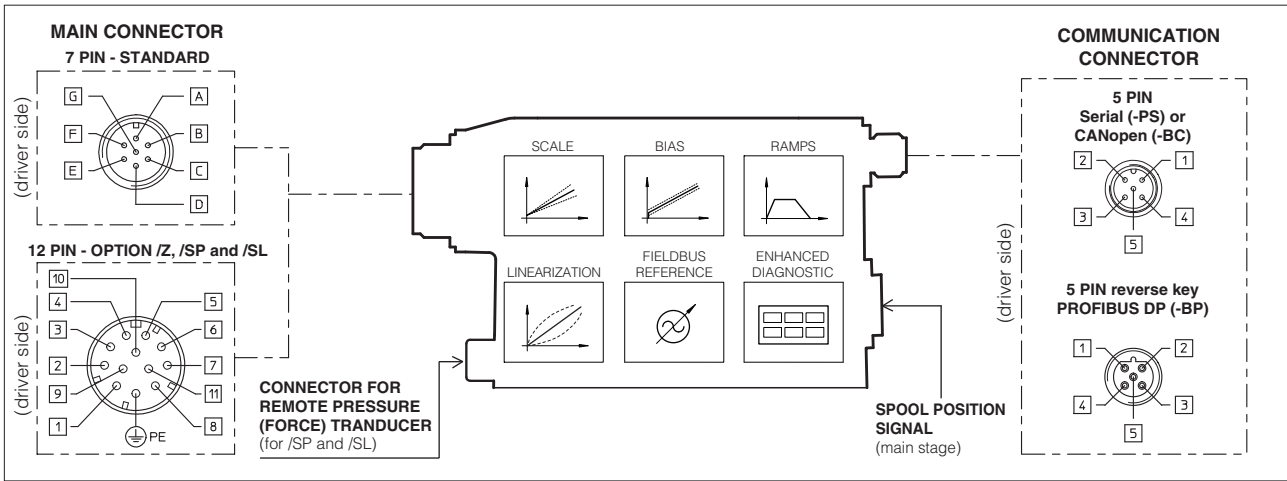

9.1 ELECTRONIC CONNECTIONS - 7 & 12 PIN MAIN CONNECTORS

Standard 7pin	/Z option 12pin	SIGNAL	TECHNICAL SPECIFICATIONS	NOTES
A	1	V+	Power supply 24 Vdc for solenoid power stage (and for driver logic on 7 pin connection)	Input - power supply
B	2	V0	Power supply 0 Vdc for solenoid power stage (and for driver logic on 7 pin connection)	Gnd - power supply
-	3	ENABLE	Enable (24 Vdc) or disable (0 Vdc) the driver	Input - on/off signal
D	4	INPUT+	Reference analog input: ± 10 Vdc maximum range (4 \div 20 mA for /I option)	Input - analog signal
E	-	INPUT -	standard: differential input; /Z option: common mode INPUT+ referred to AGND	
C	5	AGND	Ground - signal zero for MONITOR signal signal zero for INPUT+ signal (only for /Z option)	Gnd - analog signal
F	6	MONITOR	Monitor analog output: ± 10 Vdc maximum range (4 \div 20 mA for /I option)	Output - analog signal
-	7	NC	do not connect (pressure/force input for /SP and /SL options, see 8.3)	
-	8	NC	do not connect (pressure/force monitor for /SP and /SL options, see 8.3)	
-	9	VL+	Power supply 24 Vdc for driver logic	Input - power supply
-	10	VLO	Power supply 0 Vdc for driver logic	Gnd - power supply
-	11	FAULT	Fault (0V) or normal working (24V)	Output - on/off signal
G	PE	EARTH	Internally connected to the driver housing	

Note: A minimum time of 300 to 500 ms have to be considered between the driver energizing with the 24 Vdc power supply and when the valve is ready to operate. During this time the current to the valve coils is switched to zero.

9.2 ELECTRONIC CONNECTIONS - 5 PIN COMMUNICATION CONNECTORS

PIN	-PS Serial		-BC CANopen		-BP PROFIBUS DP	
	SIGNAL	TECHNICAL SPECIFICATION	SIGNAL	TECHNICAL SPECIFICATION	SIGNAL	TECHNICAL SPECIFICATION
1	NC	do not connect	CAN_SHLD	Shield	+5V	for termination
2	NC	do not connect	NC	do not connect	LINE-A	Bus line (high)
3	RS_GND	Signal zero data line	CAN_GND	Signal zero data line	DGND	data line and termination Signal zero
4	RS_RX	Valves receiving data line	CAN_H	Bus line (high)	LINE-B	Bus line (low)
5	RS_TX	Valves transmitting data line	CAN_L	Bus line (low)	SHIELD	

10 SOFTWARE TOOLS

The driver configuration and parameters can be easily set with the Atos E-SW programming software, available in three different versions according to the driver's communication execution: E-SW-PS (Serial), E-SW-BC (CANopen) and E-SW-BP (PROFIBUS DP).

For a more detailed description of software interface, PC requirements, adapters, cables and terminators, please refer to technical table G500.

Programming software, must be ordered separately:

E-SW-* (mandatory - first supply) = Dvd including E-SW-* software installer and operator manuals; it allows the registration to Atos digital service

E-SW*-N (optional - next supplies) = as above but not allowing the registration to Atos digital service

On first supply of the E-SW-* software, it is required to apply for the registration in the Atos download area: www.download.atos.com.

Once the registration is completed, the password will be sent by email.

The software remains active for 10 days from the installation date and then it stops until the user inputs his password.

With the password you can also download, in your personal area, the latest releases of the Atos software, manuals, drivers and configuration files.

11 MAIN CHARACTERISTICS OF PROPORTIONAL THROTTLE CARTRIDGE VALVES

Assembly position	Any position
Subplate surface finishing	Roughness index, Ra 0,4 flatness ratio 0,01/100 (ISO 1101)
Ambient temperature	-20°C \div +70°C for -L execution; -20°C \div +60°C for -LE and LES executions
Fluid	Hydraulic oil as per DIN 51524 ... 535 for other fluids see section 11
Recommended viscosity	15 \div 100 mm ² /s at 40°C (ISO VG 15 \div 100)
Fluid contamination class	ISO 4406 class 20/18/15 NAS 1638 class 9, in line filters of 10 μ m ($\beta_{10} \geq 75$ recommended)
Fluid temperature	-20°C +60°C (standard seals) -20°C +80°C (/PE seals)
Coil resistance R at 20°C	3 \div 3,3 Ω
Max. solenoid current	2,6 A
Max. power	35 Watt
Insulation class	H (180°) Due to the occurring surface temperatures of the solenoid coils, the European standards
Protection degree (CEI EN-60529)	ISO 13732-1 and EN982 must be taken into account IP65 for -L execution; IP67 for -LE and -LES executions
Duty factor	Continuous rating (ED=100%)

12 DIAGRAMS (based on mineral oil ISO VG 46 at 50 °C)

12.1 Regulation diagrams, see note

1 = LIQZO-L* (all sizes)

Hydraulic configuration vs. reference signal:

Reference signal 0 ÷ +10 V P → A
12 ÷ 20 mA

Reference signal 0 ÷ -10 V A → T
4 ÷ 12 mA

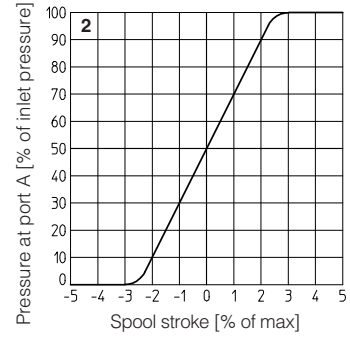
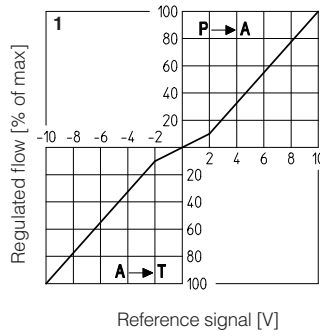

12.2 Pressure gain diagram

2 = LIQZO-L* (all sizes)

12.3 Bode diagrams

1 = LIQZO-L*-253L4: ± 90%
2 = LIQZO-L*-253L4: ± 5%

3 = LIQZO-L*-323L4: ± 90%
4 = LIQZO-L*-323L4: ± 5%

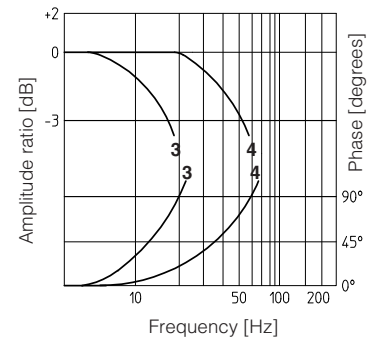
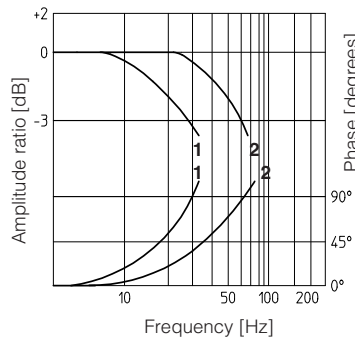

5 = LIQZO-L*-403L4: ± 90%
6 = LIQZO-L*-403L4: ± 5%

7 = LIQZP-L*-503L4: ± 90%
8 = LIQZP-L*-503L4: ± 5%

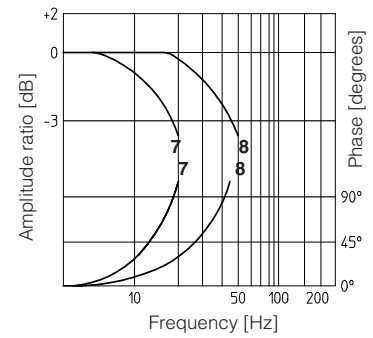
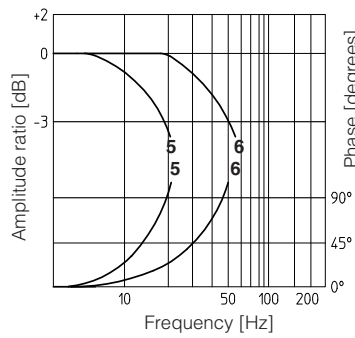

9 = LIQZP-L*-633L4: ± 90%
10 = LIQZP-L*-633L4: ± 5%

11 = LIQZP-L*-803L4: ± 90%
12 = LIQZP-L*-803L4: ± 5%

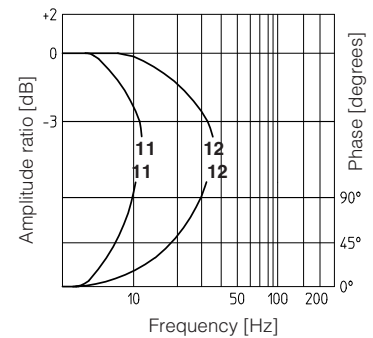
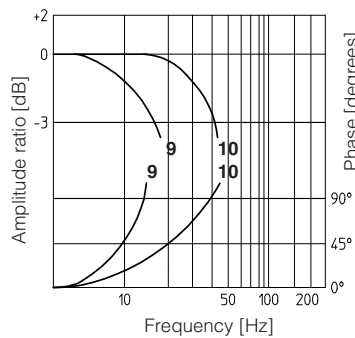

12.4 Dynamic response

The response times in section 2 and the frequency responses of the bode diagrams in sections 6.3, have to be considered as average values. For the valves with digital electronics the dynamics performances can be optimized by setting the internal software parameters.

13 AIR BLEEDING

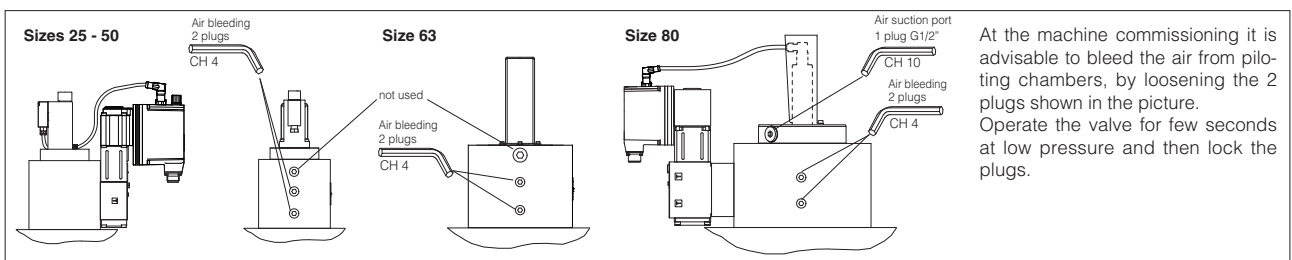

14 INSTALLATION DIMENSIONS [mm]

Size 25, 32 and 40

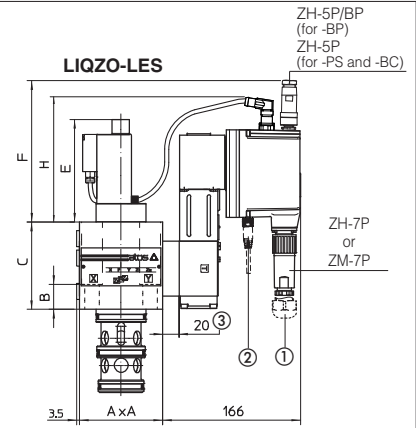
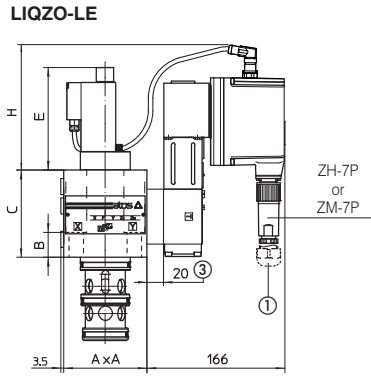
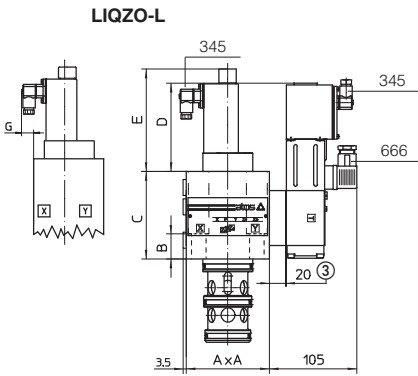

Size 50

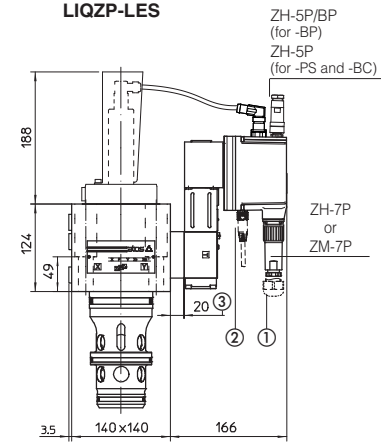
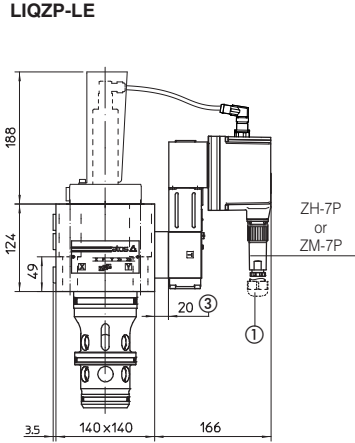
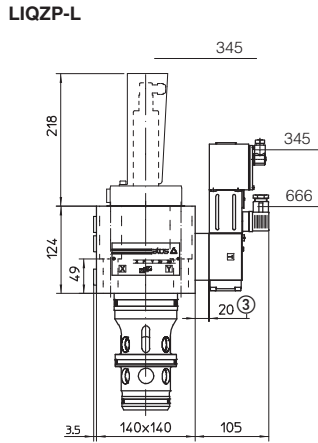

Size 63 and 80

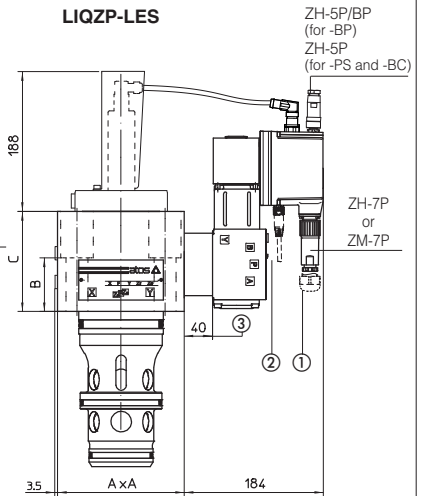
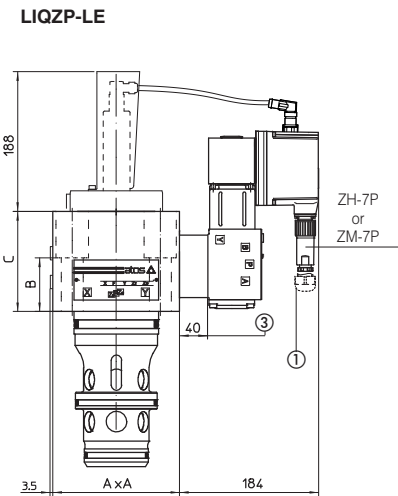
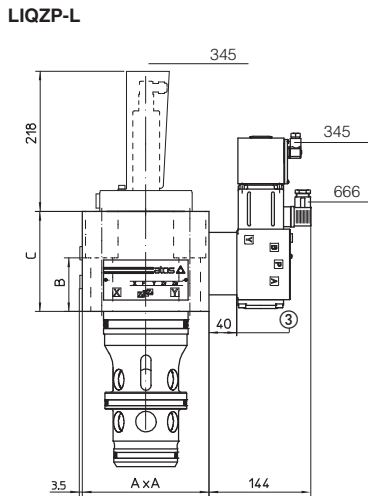

- ① Dotted line = 12 pin connector ZH-12P for options /Z
- ② Dotted line = M8 connector ZH-4P-M8/5 moulded on cable 5 mt length for pressure or force transducer (options /SL, /SP)
- ③ Intermediate plate not present for option /A

Size	A	B	C	D	E	F	G	H	Fastening bolts class 12.9	Tightening torque	Weight (Kg)	
											L	LE-LES
25	85	80	95	117	83	-	16	160	N°4 M12x100	125 Nm	9,2	9,8
32	100	30	105	106	123	140	7	150	N°4 M16x60	300 Nm	11,9	12,6
40	125	39	120	95	123	128	-	135	N°4 M20x70	600 Nm	17,7	18,3
50	see drawing								N°4 M20x80	600 Nm	24,9	25,6
63	180	76	142	-	-	-	-	-	N°4 M30x120	2100 Nm	45	47,6
80	Ø 250	45	165	-	-	-	-	-	N°8 M24x80	1000 Nm	72,6	73,3

Mounting surface: ISO 7368
(see table P006)

15 MODEL CODES OF POWER SUPPLY AND COMMUNICATION CONNECTORS (to be ordered separately)

VALVE VERSION	-L			-LE, -LES		-LE/Z	serial (-PS) or CANopen (-BC)	PROFIBUS DP (-BP)	LES /SL, /SP (transducer)
	Power supply	Transducer		ZH-7P	ZM-7P	-LES /Z, /SL, /SP			
CONNECTOR CODE	666	345	ZBE 08	ZH-7P	ZM-7P	ZH-12P	ZH-5P	ZH-5P/BP	ZH-4P-M8/5 (1)
PROTECTION DEGREE	IP65	IP65	IP67	IP67	IP67	IP67	IP67	IP67	IP67
DATA SHEET	K500			G200, G210, K500			G210, K500		G212, K500

(1) M8 connector ZH-4P-M8/5 moulded on cable 5 mt length for pressure or force transducer (options /SL, /SP)

connectors supplied with the valve